

# TECHNICAL DATA MHL 340



# TECHNICAL DATA

## OPERATING WEIGHT WITHOUT ATTACHMENTS

MHL340 E	28.0 t–29.5 t
MHL340 E FQC	28.0 t–31.8 t

## DIESEL ENGINE

Manufacturer and model	Deutz 6.1 L6
Configuration	6-cylinder inline
Engine management system	EMR IV
Type	4-stroke diesel, common rail direct injection, turbocharger, controlled exhaust gas recirculation, diesel particulate filter with automatic regeneration
Engine output power	129 kW
Nominal speed	2000 min <sup>-1</sup>
Displacement	6.1 l
Cooling system	Combi-cooler (coolant/ charge air) with fan speed control system; optional reversing function
Emission standard	COM III B / EPA Tier IV interim
Air filter design	Two-stage filter with safety cartridge and pre-separator with discharge valve
Usable tank capacity	380 l (for at least two working shifts)

## ELECTRICAL SYSTEM

Generator	28 V / 100 A
Operating voltage	24 V
Battery	2 × 12 V / 110 Ah / 760 A (in accordance with EN standards)
Lighting set	2 × H3 headlamps, turn indicators and tail lights
Optional equipment	13 kW or 17 kW generator with controls and insulation monitoring, driven by V-belt direct from diesel engine

## TRAVEL DRIVE

Hydrostatic travel drive via infinitely variable axial piston motor with directly mounted travel brake valve, two-speed manual gearshift, 4-wheel drive	
Maximum speed, 1st gear	5 km/h
Maximum speed, 2nd gear	20 km/h
Gradeability	max. 45 %
Turning radius	8.2 m

## SWING DRIVE

Swing gear	Double row, internally geared ball-race slewing ring
Drive	3-stage planetary gear with integrated multi-disc brake
Upper carriage swing speed	Infinitely variable from 0–7 rpm
Swing brake	Electrically operated
Max. swing torque	66 kNm

## UNDERCARRIAGE

Front axle	Rigid axle with integral drum brake, planetary drive, max. steering angle: 27°
Rear axle	Oscillating axle with integral drum brake and selectable oscillation lock, planetary drive
Support	4-point stabilizer system
Stabilizers	Solid rubber, 8-ply 10.00–20 for MHL340E, 12.00–20 for MHL340E FQC

## BRAKE SYSTEM

Service brake	Hydraulic single-circuit braking system acting on all four wheel pairs
Parking brake	Electrically operated disc brake on travel gearbox, acting on both front and rear axles

## HYDRAULIC SYSTEM

LINDE mobile hydraulic system with load limit control and fuelsaving power demand control. Separate hydraulic oil cooler, temperature-controlled fan speed, with optional reversing function	
Hydraulic oil filter	Integral return filter in oil tank for work hydraulics, with 3000 operating hrs service interval; oil filtration on all auxiliary circuits
Max. pump flow rate	2 × 330 l/min
Max. operating pressure	320 / 360 bar
Hydraulic oil tank	350 l usable tank capacity

## OPERATOR CAB

Elastically supported, infinitely variable hydraulically elevatable with eye level up to 5.40 m above ground; sound-insulated; heat-insulating glass panoramic windows for optimum view field; windshield with pull-down sunblind that slides under the cab roof; viewing window on cab roof; sliding window in cab door; height and tilt-adjustable steering column.	
Heating	Infinitely variable heating with 3-speed fan, 6 adjustable defroster nozzles (hot water system)
Operator's seat	Air-cushioned high-comfort seat with integrated headrest, safety belt and lumbar support, seat heating with integrated a/c function optional.  Seat position, seat inclination and seat cushion multi-adjustable relative to position of armrests and pilot control units, allowing fatigue-free operation
Monitoring	Ergonomic layout; glare-free instrumentation. Multi-function display, automatic monitoring and recording of abnormal operating conditions (including all hydraulic oil filters, hydraulic oil temperature [cold / hot] – coolant temperature and charge air temperature – condition of cooling system, diesel particulate filter load), visual and audible warning indication with shutdown of pilot controls/ engine power reduction.  Diagnosis of individual sensors available via the multi-function display.  Rear view camera
Air conditioning	Air conditioning system with automatic temperature control and climatized storage compartment
Noise level	$L_{w(A)}$ = 101 dB(A) (guaranteed) in accordance with directive 2000/14 EC

## OFFICIAL APPROVALS

Certified in accordance with CE regulations
---

# EQUIPMENT

## ENGINE

	STANDARD	OPTIONAL
Exhaust gas turbocharger	●	
Charge air cooling	●	
Direct electronic fuel injection/ common rail	●	
Automatic idle	●	
Engine preheating		●
Engine diagnostics interface	●	
System-controlled fan drive with fan speed monitoring	●	

## CAB

Cab elevation system	●	
Safety glass	●	
Hinged windscreen	●	
Sliding window in cab door	●	
Glazed roof panel	●	
Hinged roof opening	●	
Armoured glass (windscreen and roof panel)		●
Armoured glass (windscreen and roof panel) MHL340 FQC	●	
Windscreen washer system	●	
Washer system installed underneath windscreen		●
Air-cushioned operator seat with headrest, seatbelt, and lumbar support	●	
Seat heating with integrated a/c function		●
Steering column, height and tilt adjustable	●	
Automatic air conditioning system	●	
Independent heating system		●
Multi-function display	●	
Document clip	●	
Protective grilles to front and roof		●
12V transformer		●
Radio CD player		●
12V power outlet		●
Fire extinguisher, dry powder		●
Rotating beacon		●

## SUPERSTRUCTURE

Separate cooling systems (combi-cooler for engine and hydraulic oil cooler)	●	
Cooling system fan speeds controlled by operating parameters	●	
Fan drive reversing function		●
Lockable maintenance hatches, with gas struts	●	
Automatic central lubrication system	●	
Rear view camera	●	
Reversing alarm		●
Electric refuelling pump		●
Lighting protection		●
Special paint		●

## SUPERSTRUCTURE

	STANDARD	OPTIONAL
Quick-drain valve for		
Hydraulic oil tank	●	
Diesel tank	●	
Engine oil pan	●	

## UNDERCARRIAGE

4-wheel differential drive	●	
Drum brakes	●	
Rear axle oscillating lock	●	
2-speed manual transmission	●	
2-speed powershift transmission		●
4-point stabilizers	●	
Stabilizer cylinders with integrated two-way check valves	●	
Piston rod protection on stabilizer cylinders	●	
Stabilizer plates 350 × 500	●	
4-point stabilizers, individually controllable		●
Dozer blade with plastic or Hardox edge (in addition to 4-point stabilizers)		●
Tool box	●	
Special paint		●

## EQUIPMENT

13 kW DC generator with controls and insulation monitoring		●
17 kW DC generator with controls and insulation monitoring		●
Close proximity range limiter for dipper stick	●	
Coolant and hydraulic oil level monitoring system	●	
Filter system for attachments		●
Filter system for attachments MHL340 FQC	●	
Hose rupture protection for lift cylinder		●
Hose rupture protection for dipperstick cylinder		●
Overload warning device		●
Quick coupling on dipperstick	●	
Cut-off ball valve on dipperstick		●
Dipperstick impact protection		●
Cyclonic pre-separator for air-filter		●
Hydraulic oil preheating		●
Float switch		●
Joystick steering		●
Central lubrication system for grab suspension lubrication	●	
H3 headlamps	●	
H3 worklights on boom and dipperstick (up to 4)		●
Xenon worklights on boom and dipperstick (up to 4)		●
Front-mounted Xenon worklights (up to 2)		●
Xenon worklights on cab roof (up to 4)		●

More special equipment available on request!

# DIMENSIONS

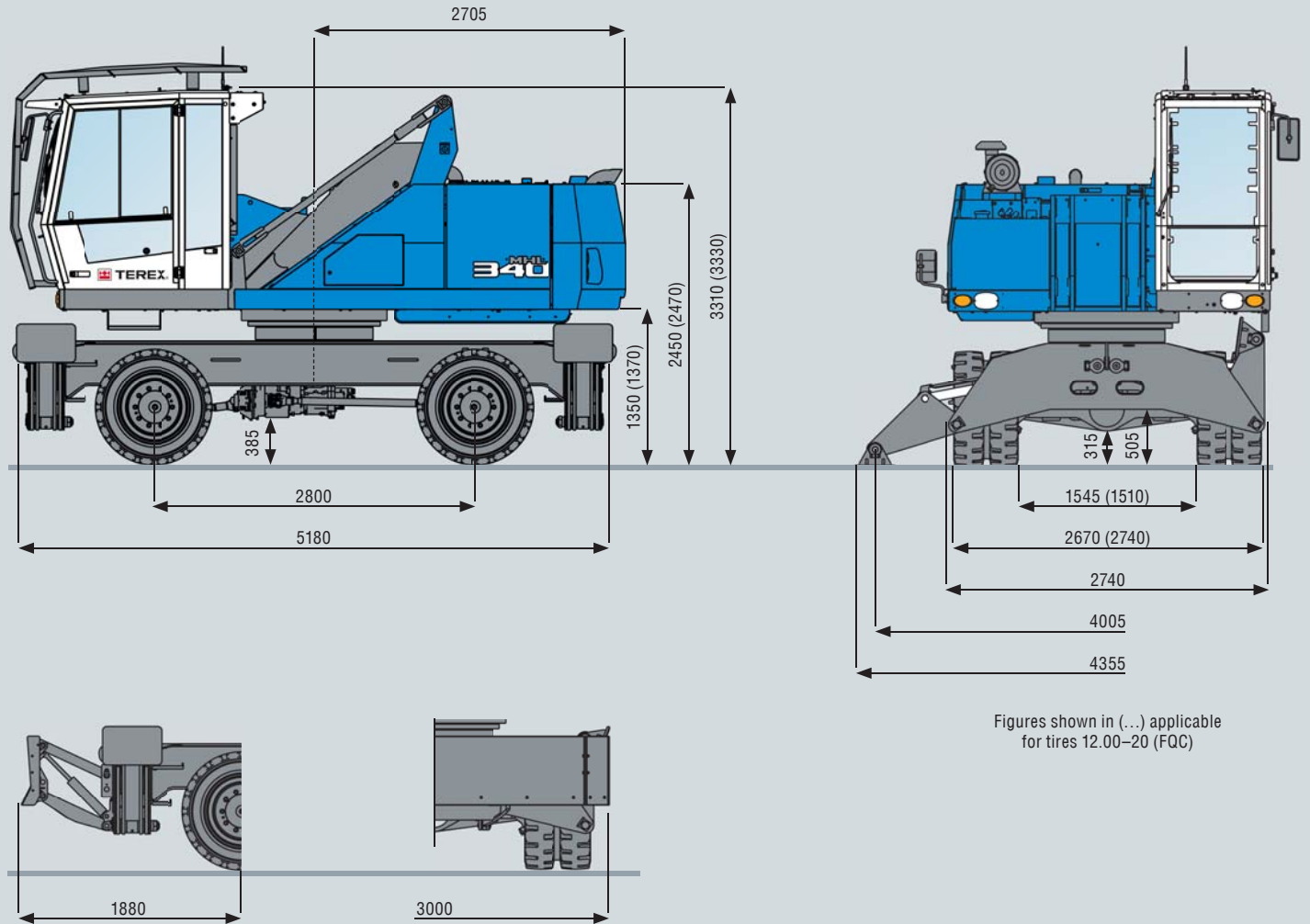

Figures shown in (...) applicable for tires 12.00-20 (FQC)

# TRANSPORT DIMENSIONS MHL340 E

Loading system 13,7 m cranked: Undercarriage equipped with dozer blade, rotated by 180°

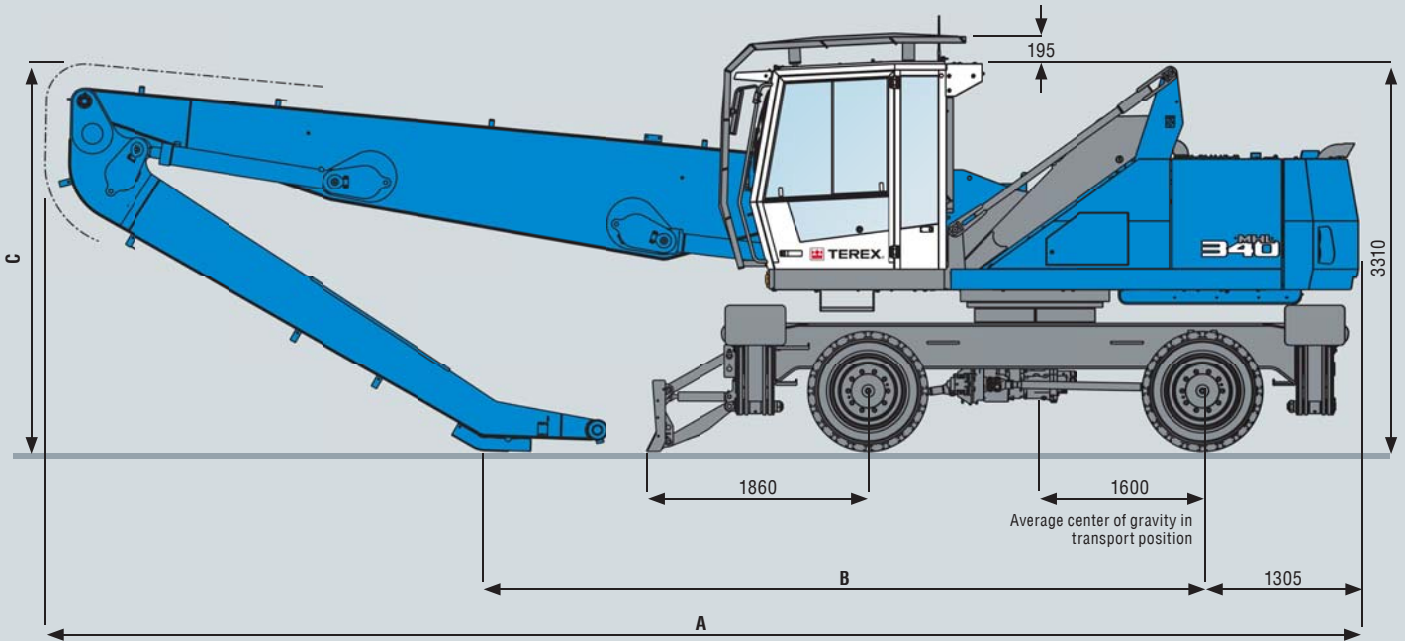

Dimension	Reach 12.2 m (MZS)	Reach 12.6 m	Reach 13.7 m
A	10340 mm	11000 mm	10980 mm
B	6020 mm	5820 mm	5045 mm
C	2760 mm	2940 mm	3770 mm

# TRANSPORT DIMENSIONS MHL340 E FQC

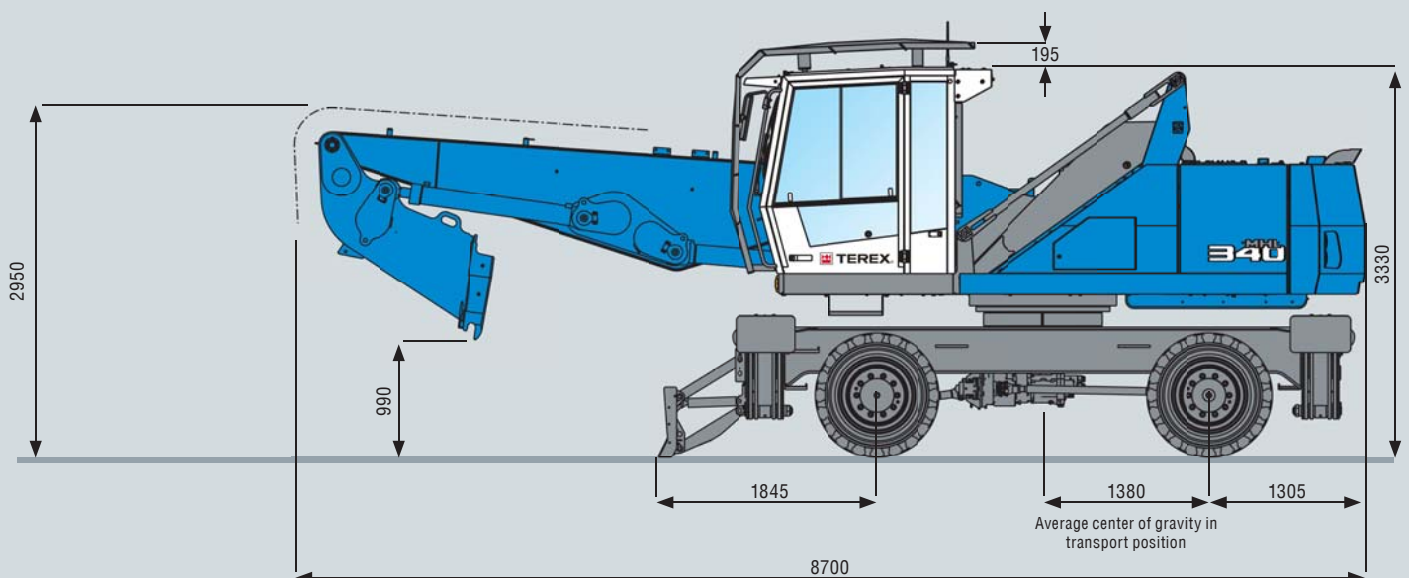

# WORKING RANGES / LOAD CAPACITIES

## 12.6 M REACH WITH DIPPERSTICK

<b>Loading system</b>	Boom 7.2 m Dipperstick 5.1 m Cactus grab 0.6 m <sup>3</sup> open
-----------------------	--

## RECOMMENDED ATTACHMENTS

<b>Terex® Fuchs cactus grab 0.4 m<sup>3</sup></b>	Open or half-closed
<b>Terex® Fuchs cactus grab 0.6 m<sup>3</sup></b>	Open or half-closed
<b>Terex® Fuchs cactus grab 0.8 m<sup>3</sup></b>	Open or half-closed
<b>Terex® Fuchs magnetic plate MP 1150</b>	dia = 1150 mm with 13 kW magnet system
<b>Terex® Fuchs magnetic plate MP 1350</b>	dia = 1350 mm with 17 kW magnet system
<b>Clamshell grab 1.0 m<sup>3</sup></b>	Density of materials handled up to 1400 kg/m <sup>3</sup>
<b>Clamshell grab 1.6 m<sup>3</sup></b>	Density of materials handled up to 800 kg/m <sup>3</sup>
<b>Lift hook</b>	10 t

The lift capacity values are stated in metric tons (t). The pump pressure is 360 bar. In accordance with ISO 10567 the lift capacity values represents 75% of the static tipping loads or 87% of the hydraulic lifting force (marked °). On solid and level ground the values apply to a swing range of 360°. The (...) values apply in the longitudinal direction of the undercarriage. The values for "not supported" only apply via the steering axle or the locked oscillating axle. The weights of the attached load hoisting equipment (grab, load hook, etc.) must be deducted from the lift capacity values. The working load of the lifting device must be observed. In accordance with the EN 474-5 for object handling application hose rupture valves on the boom and stick cylinders, an overload warning device and the lift capacity table in the cab are required. For object handling application the machine has to be supported on a level ground.

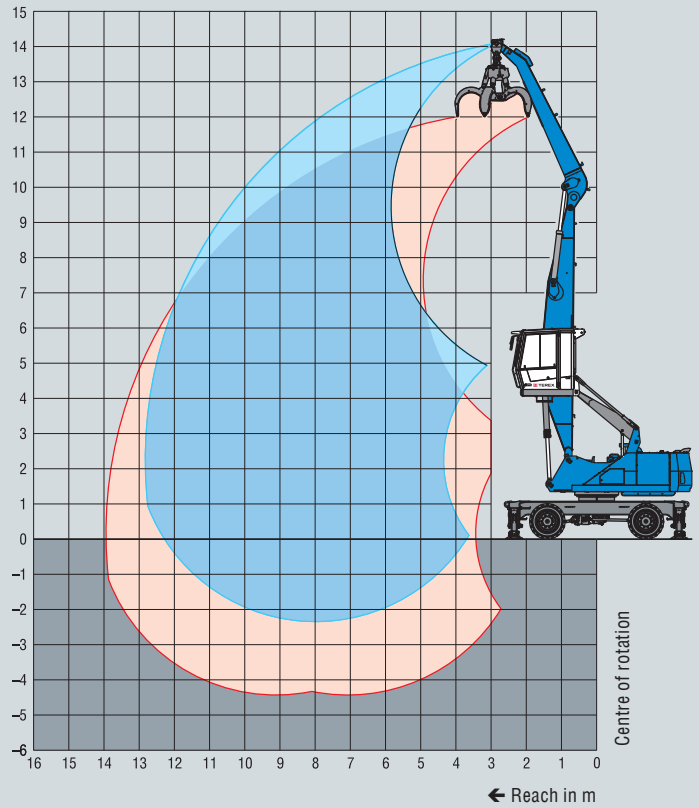

Height [m]	Undercarriage stabilisation	Reach [m]					
		4.5	6	7.5	9	10.5	12
13.5	Without stabilizers	(7.2°)					
	With 4-pt stabilizers	7.2° (7.2°)					
12	Without stabilizers		(7.3)	(4.9)			
	With 4-pt stabilizers		7.7° (7.7°)	5.3° (5.3°)			
10.5	Without stabilizers		(7.5)	(5.1)	(3.7)		
	With 4-pt stabilizers		8.8° (8.8°)	7.6° (7.6°)	5.4° (5.4°)		
9	Without stabilizers		(7.5)	(5.2)	(3.8)	(2.8)	
	With 4-pt stabilizers		8.8° (8.8°)	7.5° (7.5°)	5.7 (6.6°)	4.4 (4.4°)	
7.5	Without stabilizers		(7.3)	(5.1)	(3.7)	(2.8)	
	With 4-pt stabilizers		9.0° (9.0°)	7.6° (7.6°)	5.7 (6.6°)	4.4 (5.4)	
6	Without stabilizers		(7.0)	(4.9)	(3.6)	(2.8)	(2.2)
	With 4-pt stabilizers		9.6° (9.6°)	7.5 (7.9°)	5.6 (6.7°)	4.3 (5.4)	3.5 (4.3°)
4.5	Without stabilizers	(10.3)	(6.5)	(4.6)	(3.5)	(2.7)	(2.1)
	With 4-pt stabilizers	14.0° (14.0°)	10.4° (10.4°)	7.2 (8.3°)	5.4 (6.7)	4.2 (5.3)	3.4 (4.3)
3	Without stabilizers	(9.0)	(5.9)	(4.3)	(3.3)	(2.6)	(2.1)
	With 4-pt stabilizers	15.7° (15.7°)	9.7 (11.0°)	6.9 (8.6°)	5.2 (6.5)	4.1 (5.2)	3.4 (4.2)
1.5	Without stabilizers	(6.1°)	(5.5)	(4.0)	(3.1)	(2.5)	(2.0)
	With 4-pt stabilizers	6.1° (6.1°)	9.2 (11.2°)	6.6 (8.4)	5.0 (6.3)	4.0 (5.1)	3.3 (4.2)
0	Without stabilizers	(5.3°)	(5.2)	(3.8)	(3.0)	(2.4)	(2.0)
	With 4-pt stabilizers	5.3° (5.3°)	8.8 (10.6°)	6.3 ( 8.1°)	4.9 (6.2)	3.9 (4.9)	3.3 (3.9°)
-1.5	Without stabilizers		(5.0)	(3.7)	(2.9)	(2.4)	
	With 4-pt stabilizers		8.7 (9.1°)	6.2 (7.3°)	4.8 (5.8°)	3.9 (4.5°)	
<b>Reach max. 12.8</b>							
2.2	Without stabilizers						(1.8)
	With 4-pt stabilizers						3.0 (3.3°)

## 13.7 M REACH WITH DIPPERSTICK

Loading system	Boom 7.2m
	Dipperstick 6.2m
	Cactus grab 0.6m³ open

## RECOMMENDED ATTACHMENTS

Terex® Fuchs cactus grab 0.4 m³	Open or half-closed
Terex® Fuchs cactus grab 0.6 m³	Open or half-closed
Terex® Fuchs magnetic plate MP 1150	dia = 1150 mm with 13 kW magnet system
Terex® Fuchs magnetic plate MP 1350	dia = 1350 mm with 17 kW magnet system
Clamshell grab 1.0 m³	Density of materials handled up to 1400 kg/m³
Lift hook	10 t

The lift capacity values are stated in metric tons (t). The pump pressure is 360 bar. In accordance with ISO 10567 the lift capacity values represents 75% of the static tipping loads or 87% of the hydraulic lifting force (marked °). On solid and level ground the values apply to a swing range of 360°. The (...) values apply in the longitudinal direction of the undercarriage. The values for "not supported" only apply via the steering axle or the locked oscillating axle. The weights of the attached load hoisting equipment (grab, load hook, etc.) must be deducted from the lift capacity values. The working load of the lifting device must be observed. In accordance with the EN 474-5 for object handling application hose rupture valves on the boom and stick cylinders, an overload warning device and the lift capacity table in the cab are required. For object handling application the machine has to be supported on a level ground.

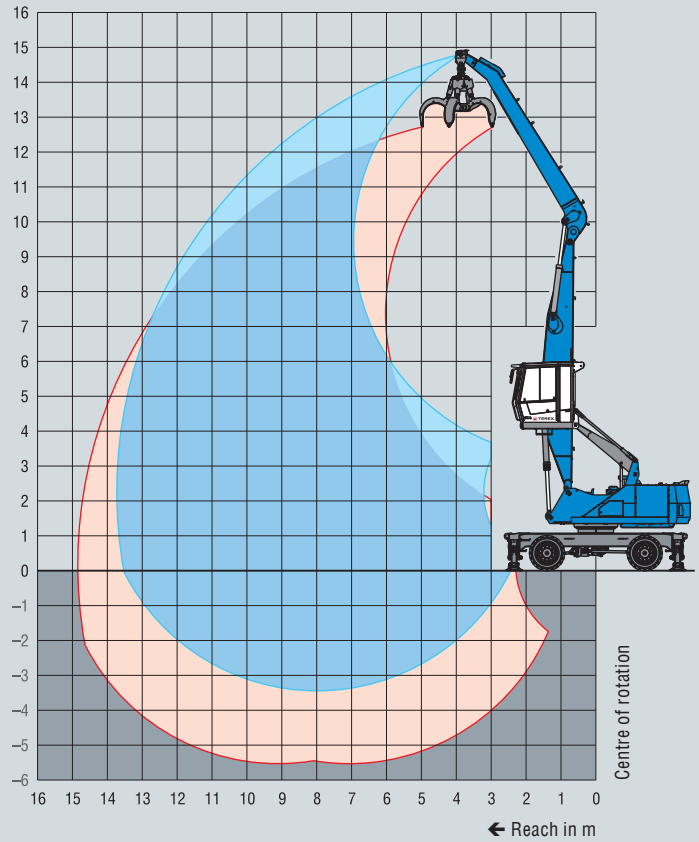

Height [m]	Undercarriage stabilisation	Reach [m]						
		4.5	6	7.5	9	10.5	12	13.5
13.5	Without stabilizers		(5.2°)					
	With 4-pt stabilizers		5.2° (5.2°)					
12	Without stabilizers			(5.3)	(3.5°)			
	With 4-pt stabilizers			5.4° (5.4°)	3.5° (3.5°)			
10.5	Without stabilizers			(5.4)	(3.9)	(2.9)		
	With 4-pt stabilizers			6.4° (6.4°)	5.3° (5.3°)	3.2° (3.2°)		
9	Without stabilizers			(5.4)	(3.9)	(2.9)		
	With 4-pt stabilizers			6.8° (6.8°)	5.9 (6.1°)	4.5 (4.9°)		
7.5	Without stabilizers			(5.3)	(3.8)	(2.9)	(2.2)	
	With 4-pt stabilizers			6.9° (6.9°)	5.8 (6.1°)	4.5 (5.5°)	3.5 (3.8°)	
6	Without stabilizers		(7.4)	(5.1)	(3.7)	(2.8)	(2.2)	
	With 4-pt stabilizers		8.6° (8.6°)	7.3° (7.3°)	5.7 (6.3°)	4.4 (5.4)	3.5 (4.3)	
4.5	Without stabilizers		(6.9)	(4.8)	(3.5)	(2.7)	(2.1)	(1.7)
	With 4-pt stabilizers		9.4° (9.4°)	7.4 (7.7°)	5.5 (6.5°)	4.3 (5.3)	3.4 (4.3)	2.4° (2.4°)
3	Without stabilizers	(9.8)	(6.3)	(4.4)	(3.3)	(2.6)	(2.0)	(1.6)
	With 4-pt stabilizers	14.2° (14.2°)	10.1 (10.3°)	7.0 (8.1°)	5.3 (6.6°)	4.1 (5.2)	3.3 (4.2)	2.7 (3.1°)
1.5	Without stabilizers	(8.5)	(5.6)	(4.1)	(3.1)	(2.4)	(1.9)	(1.6)
	With 4-pt stabilizers	15.1 (15.6°)	9.4 (10.9°)	6.6 (8.4°)	5.0 (6.3)	4.0 (5.0)	3.2 (4.1)	2.7 (3.2°)
0	Without stabilizers	(7.6°)	(5.1)	(3.8)	(2.9)	(2.3)	(1.9)	(1.6)
	With 4-pt stabilizers	7.6° (7.6°)	8.8 (10.8°)	6.3 (8.1)	4.8 (6.1)	3.9 (4.9)	3.2 (4.0)	2.7 (2.8°)
-1.5	Without stabilizers	(6.7°)	(4.9)	(3.6)	(2.8)	(2.2)	(1.9)	
	With 4-pt stabilizers	6.7° (6.7°)	8.5 (10.0°)	6.1 (7.8°)	4.7 (6.0)	3.8 (4.8)	3.1 (3.8°)	
-3	Without stabilizers		(4.8)	(3.5)	(2.7)			
	With 4-pt stabilizers		8.4° (8.4°)	6.0 (6.7°)	4.6 (5.3°)			
<b>Reach max. 13.7</b>								
2.2	Without stabilizers							(1.5)
	With 4-pt stabilizers							2.4° (2.4°)

# WORKING RANGES / LOAD CAPACITIES

## 12.2 M REACH WITH MULTI-PURPOSE STICK

Loading system	Boom 7.2 m
	Multi-purpose stick 4.5 m
	Sorting grab

The lift capacity values are stated in metric tons (t). The pump pressure is 360 bar. In accordance with ISO 10567 the lift capacity values represents 75% of the static tipping loads or 87% of the hydraulic lifting force (marked °). On solid and level ground the values apply to a swing range of 360°. The (...) values apply in the longitudinal direction of the undercarriage. The values for "not supported" only apply via the steering axle or the locked oscillating axle. The weights of the attached load hoisting equipment (grab, load hook, etc.) must be deducted from the lift capacity values. The working load of the lifting device must be observed. In accordance with the EN 474-5 for object handling application hose rupture valves on the boom and stick cylinders, an overload warning device and the lift capacity table in the cab are required. For object handling application the machine has to be supported on a level ground.

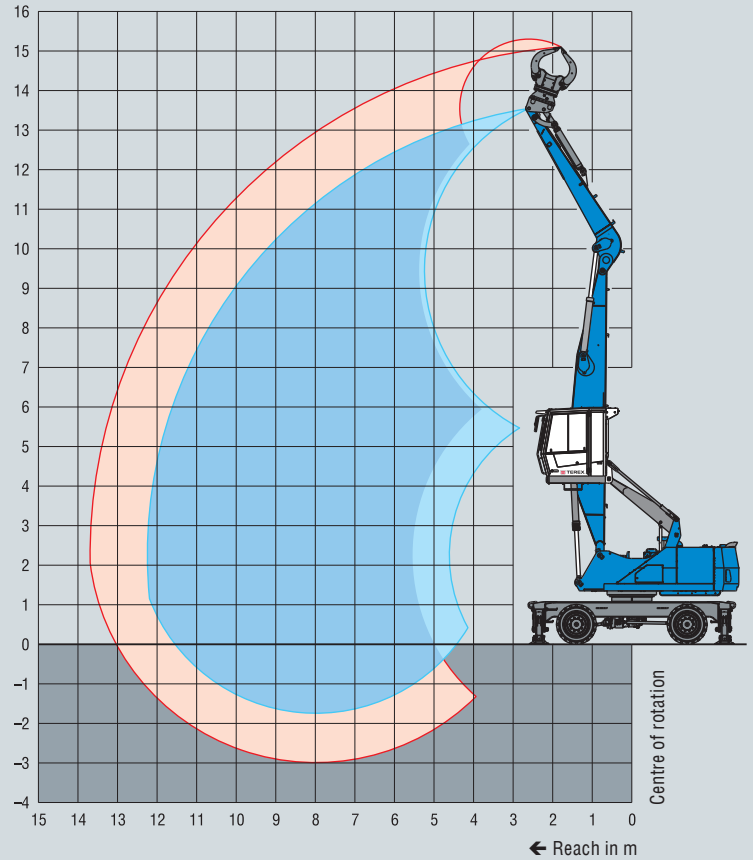

Height [m]	Undercarriage stabilisation	Reach [m]					
		4.5	6	7.5	9	10.5	12
12	Without stabilizers		(6.5°)				
	With 4-pt stabilizers		6.5° (6.5°)				
10.5	Without stabilizers		(7.1)	(4.7)			
	With 4-pt stabilizers		8.4° (8.4°)	6.7° (6.7°)			
9	Without stabilizers		(7.1)	(4.8)	(3.4)		
	With 4-pt stabilizers		9.0° (9.0°)	7.5 (7.5°)	5.4 (6.4°)		
7.5	Without stabilizers		(6.9)	(4.7)	(3.4)	(2.5)	
	With 4-pt stabilizers		9.2° (9.2°)	7.4 (7.6°)	5.3 (6.5°)	4.0 (5.1°)	
6	Without stabilizers	(10.6)	(6.5)	(4.5)	(3.3)	(2.4)	
	With 4-pt stabilizers	12.3° (12.3°)	9.7° (9.7°)	7.1 (7.8°)	5.2 (6.5°)	4.0 (5.0)	
4.5	Without stabilizers	(9.5)	(6.0)	(4.2)	(3.1)	(2.4)	(1.8)
	With 4-pt stabilizers	14.4° (14.4°)	9.8 (10.3°)	6.8 (8.1°)	5.0 (6.4)	3.9 (4.9)	3.1 (3.2°)
3	Without stabilizers		(5.4)	(3.9)	(2.9)	(2.3)	(1.8)
	With 4-pt stabilizers		9.1 (10.8°)	6.4 (8.2°)	4.8 (6.2)	3.8 (4.8)	3.1 (3.9)
1.5	Without stabilizers		(4.9)	(3.6)	(2.7)	(2.2)	(1.7)
	With 4-pt stabilizers		8.6 (10.6°)	6.1 (7.9)	4.7 (6.0)	3.7 (4.7)	3.0 (3.7)
0	Without stabilizers	(4.1°)	(4.6)	(3.4)	(2.6)	(2.1)	
	With 4-pt stabilizers	4.1° (4.1°)	8.3 (9.5°)	5.9 (7.4°)	4.5 (5.8)	3.6 (4.6°)	
-1.5	Without stabilizers			(3.3)	(2.6)		
	With 4-pt stabilizers			5.8 (6.3°)	4.5 (5.9°)		
		<b>Reach max. 12.2</b>					
2.2	Without stabilizers						(1.7)
	With 4-pt stabilizers						2.9 (3.2)

## 11.0 M REACH WITH DIPPERSTICK

### Loading system FQC

Boom 5.2 m  
 Dipperstick 5.4 m  
 Cactus grab 0.6 m<sup>3</sup> open  
 with Fuchs QuickConnect (FQC)

The lift capacity values are stated in metric tons (t). The pump pressure is 360 bar. In accordance with ISO 10567 the lift capacity values represents 75% of the static tipping loads or 87% of the hydraulic lifting force (marked °). On solid and level ground the values apply to a swing range of 360°. The (...) values apply in the longitudinal direction of the undercarriage. The values for "not supported" only apply via the steering axle or the locked oscillating axle. The weights of the attached load hoisting equipment (grab, load hook, etc.) must be deducted from the lift capacity values. The working load of the lifting device must be observed. In accordance with the EN 474-5 for object handling application hose rupture valves on the boom and stick cylinders, an overload warning device and the lift capacity table in the cab are required. For object handling application the machine has to be supported on a level ground.

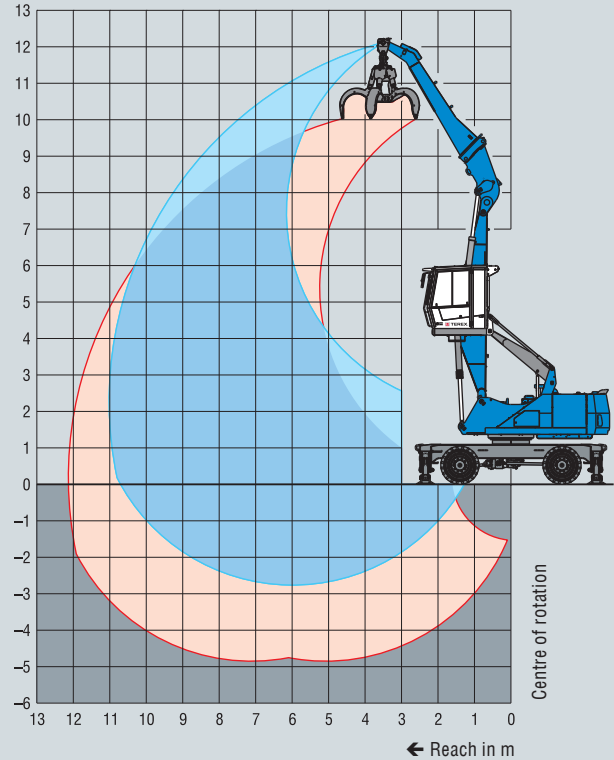

Height [m]	Undercarriage stabilisation	Reach [m]					
		3	4.5	6	7.5	9	10.5
10.5	Without stabilizers			(5.0°)			
	With 4-pt stabilizers			5.0° (5.0°)			
9	Without stabilizers			(6.6°)	(4.9°)		
	With 4-pt stabilizers			6.6° (6.6°)	4.9° (4.9°)		
7.5	Without stabilizers				(5.2)	(3.7)	
	With 4-pt stabilizers				6.3° (6.3°)	4.0° (4.0°)	
6	Without stabilizers			(7.7)	(5.2)	(3.7)	
	With 4-pt stabilizers			8.0° (8.0°)	7.3° (7.3°)	5.5° (5.5°)	
4.5	Without stabilizers			(7.3)	(5.0)	(3.6)	(2.6)
	With 4-pt stabilizers			9.0° (9.0°)	7.7° (7.7°)	5.7° (6.7°)	3.3° (3.3°)
3	Without stabilizers		(11.1)	(6.8)	(4.7)	(3.4)	(2.6)
	With 4-pt stabilizers		11.8° (11.8°)	10.0° (10.0°)	7.5 (8.1°)	5.5 (6.8°)	4.2° (4.2°)
1.5	Without stabilizers	(19.6)	(9.7)	(6.2)	(4.3)	(3.2)	(2.5)
	With 4-pt stabilizers	25.5° (25.5°)	15.1° (15.1°)	10.3 (10.9°)	7.1 (8.5°)	5.3 (6.7°)	4.1 (5.2°)
0	Without stabilizers	(7.7°)	(8.7)	(5.7)	(4.1)	(3.1)	(2.5)
	With 4-pt stabilizers	7.7° (7.7°)	15.8° (15.8°)	9.6 (11.0°)	6.8 (8.3°)	5.1 (6.4°)	3.9° (3.9°)
-1.5	Without stabilizers	(7.0°)	(8.2)	(5.4)	(3.9)	(3.0)	
	With 4-pt stabilizers	7.0° (7.0°)	14.3° (14.3°)	9.3 (10.1°)	6.6 (7.5°)	5.1 (5.4°)	
		<b>Reach max. 11.0</b>					
2.3	Without stabilizers						(2.3°)
	With 4-pt stabilizers						2.3° (2.3°)

# WORKING RANGES / LOAD CAPACITIES

## 11.2 M REACH WITH MULTI-PURPOSE STICK

<b>Loading system FQC</b>	Boom 5.2 m
	Multi-purpose stick 5.6 m
	Sorting grab with Fuchs QuickConnect (FQC)

The lift capacity values are stated in metric tons (t). The pump pressure is 360 bar. In accordance with ISO 10567 the lift capacity values represents 75% of the static tipping loads or 87% of the hydraulic lifting force (marked °). On solid and level ground the values apply to a swing range of 360°. The (...) values apply in the longitudinal direction of the undercarriage. The values for "not supported" only apply via the steering axle or the locked oscillating axle. The weights of the attached load hoisting equipment (grab, load hook, etc.) must be deducted from the lift capacity values. The working load of the lifting device must be observed. In accordance with the EN 474-5 for object handling application hose rupture valves on the boom and stick cylinders, an overload warning device and the lift capacity table in the cab are required. For object handling application the machine has to be supported on a level ground.

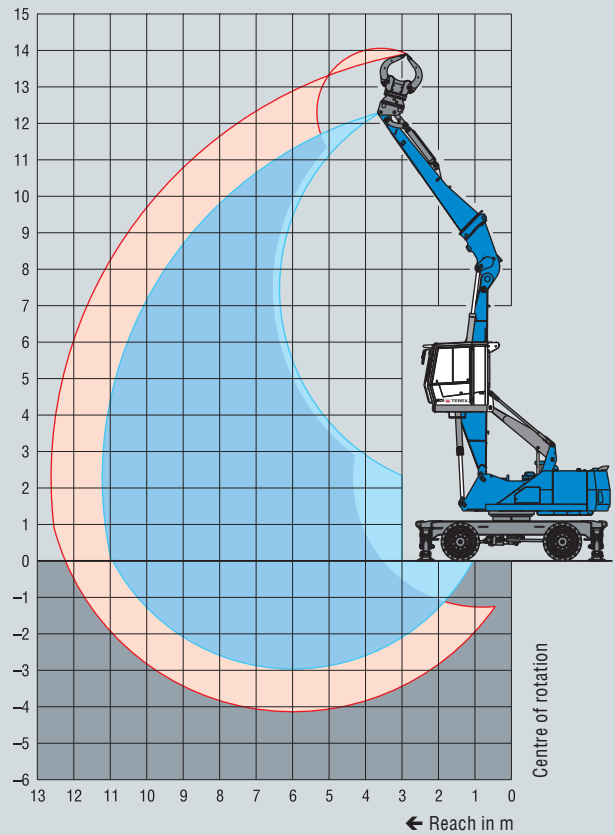

Height [m]	Undercarriage stabilisation	Reach [m]					
		3	4.5	6	7.5	9	10.5
10.5	Without stabilizers			(5.0°)			
	With 4-pt stabilizers			5.0° (5.0°)			
9	Without stabilizers				(4.8°)		
	With 4-pt stabilizers				4.8° (4.8°)		
7.5	Without stabilizers				(5.1)	(3.5)	
	With 4-pt stabilizers				5.9° (5.9°)	4.0° (4.0°)	
6	Without stabilizers				(5.0)	(3.5)	(2.0°)
	With 4-pt stabilizers				6.8° (6.8°)	5.3° (5.3°)	2.0° (2.0°)
4.5	Without stabilizers			(7.2)	(4.8)	(3.4)	(2.5)
	With 4-pt stabilizers			8.4° (8.4°)	7.3° (7.3°)	5.5 (6.3°)	3.4 (3.4°)
3	Without stabilizers		(10.2°)	(6.7)	(4.5)	(3.2)	(2.4)
	With 4-pt stabilizers		10.2° (10.2°)	9.4° (9.4°)	7.3 (7.7°)	5.3 (6.4°)	4.0 (4.2°)
1.5	Without stabilizers	(20.0)	(9.7)	(6.0)	(4.2)	(3.0)	(2.3)
	With 4-pt stabilizers	24.3° (24.3°)	14.4° (14.4°)	10.1 (10.3°)	7.0 (8.0°)	5.1 (6.4°)	3.9 (4.6°)
0	Without stabilizers	(8.1°)	(8.5)	(5.5)	(3.9)	(2.9)	(2.2)
	With 4-pt stabilizers	8.1° (8.1°)	15.4° (15.4°)	9.5 (10.6°)	6.6 (8.0°)	4.9 (6.1°)	3.9 (4.2°)
-1.5	Without stabilizers	(6.8°)	(7.9)	(5.1)	(3.7)	(2.7)	
	With 4-pt stabilizers	6.8° (6.8°)	14.2° (14.2°)	9.1 (9.9°)	6.4 (7.3°)	4.8 (5.3°)	
							<b>Reach max. 11.2</b>
2.3	Without stabilizers						(1.9°)
	With 4-pt stabilizers						1.9° (1.9°)

## WITH SCRAP SHEARS

<b>Loading system FQC</b>	Boom 5.2 m Scrap shears GXP 300 with Fuchs QuickConnect (FQC)
<b>Cutting force</b>	5749 kN
<b>Jaw depth</b>	610 mm
<b>Jaw opening</b>	584 mm
<b>Weight*</b>	4 t

\* including quick change system

The lift capacity values are stated in metric tons (t). The pump pressure is 360 bar. In accordance with ISO 10567 the lift capacity values represents 75% of the static tipping loads or 87% of the hydraulic lifting force (marked °). On solid and level ground the values apply to a swing range of 360°. The (...) values apply in the longitudinal direction of the undercarriage. The values for "not supported" only apply via the steering axle or the locked oscillating axle. The weights of the attached load hoisting equipment (grab, load hook, etc.) must be deducted from the lift capacity values. The working load of the lifting device must be observed. In accordance with the EN 474-5 for object handling application hose rupture valves on the boom and stick cylinders, an overload warning device and the lift capacity table in the cab are required. For object handling application the machine has to be supported on a level ground.

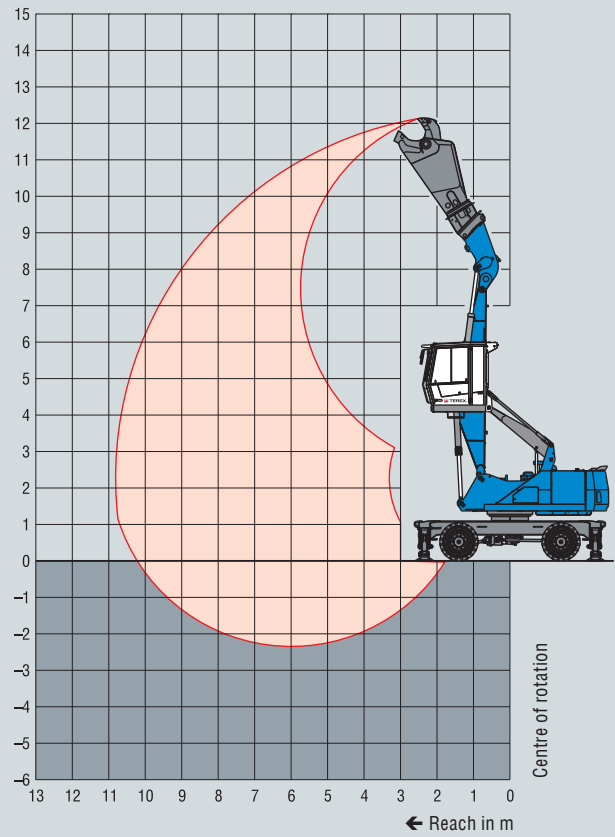

[www.terex-fuchs.com](http://www.terex-fuchs.com)

Effective starting: February 2013. Product specifications and prices are subject to change without notice or obligation. The photographs and/or drawings in this document are for illustrative purposes only. Refer to the appropriate Operator's Manual for instructions on the proper use of this equipment. Failure to follow the appropriate Operator's Manual when using our equipment or to otherwise act irresponsibly may result in serious injury or death. The only warranty applicable to our equipment is the standard written warranty applicable to the particular product and sale and Terex makes no other warranty, express or implied. Products and services listed may be trademarks, service marks or trade-names of Terex Corporation and/or its subsidiaries in the USA and other countries. All rights are reserved. Terex is a registered trademark of Terex Corporation in the USA and many other countries. © 2013 Terex Corporation.



**WORKS FOR YOU.™**